



# Lower Maintenance Costs\*

Philips Advance programmed start parallel Optanium ballasts for T8 lamps helps lower maintenance costs with independent lamp operation.

Philips Advance Optanium high-efficiency programmed start parallel ballasts are now available in a 347V version. These ballast are parallel wired instead of series wired which provides independent lamp operation within the fixture. When one lamp reaches its End-Of-Life (EOL) the remaining lamps stay lit, as a result less lamps are replaced because the end user can tell which lamp has reached EOL. With more lamps remaining on, this reduces the urgency of re-lamping and produces less dark spots in fixtures during EOL .

These ballast join our premium line of Optanium high-efficiency electronic ballasts which are engineered to optimize lighting performance and maximize energy savings. They provide an exceptional package of features and benefits to support the wide variety of T8 fluorescent lamps out in the market place. They are also part of our offering of the NEMA Premium® ballast high efficiency program as well as meeting CEE high performance T8 lighting specifications.

These ballasts are an optimal choice with occupancy sensors or in frequent switching applications for a range of new construction and retrofit applications within the commercial sector including general office lighting, institutional, government, health care and school applications.

- **Independent Lamp Operation**

Helps reduce maintenance costs as more lamps remain on when lamps reach end-of-life minimizing wasteful re-lamping

- **Faster Starting Programmed Start**

Reduces the likelihood of striation in energy-saving lamps, allowing for additional energy-saving opportunities

- **Enhanced Two-Level Switching**

Allows users to replace lamps without cycling power (standard and energy saving lamps)

\* Based on the properties of independent lamp operation allowing you to replace only the failed lamps.

**PHILIPS**  
**ADVANCE**  
sense and simplicity

## Philips Advance Optanium

Number	Input Volts	Starting Method	Ballast Family	Catalog Number	Input Power ANSI (Watts)	Ballast Factor	Max. THD %	Line Current (Amps)	Min. Starting Temp (F/C)	Dim.	Wiring Dia.
<b>F17T8 (17W)</b>											
1	347	PS	Optanium	GOP-2PSP32-SC	19	1.08	10	0.06	0/-18	B	1
2	347	PS	Optanium	GOP-2PSP32-SC	31	0.88		0.09	0/-18		
<b>F25T8 (25W)</b>											
1	347	PS	Optanium	GOP-2PSP32-SC	26	1.05	10	0.08	0/-18	B	1
2	347	PS	Optanium	GOP-2PSP32-SC	43	0.88		0.12	0/-18		
<b>F32T8, FB032T8, F32T8/U6 (32W)</b>											
1	347	PS	Optanium	GOP-2PSP32-SC	34	1.03	10	0.10	0/-18	B	1
2	347	PS	Optanium	GOP-2PSP32-SC	57	0.88		0.17	0/-18		
<b>F32T8/ES (25W)</b>											
1	347	PS	Optanium	GOP-2PSP32-SC	28	1.04	10	0.08	60/16	B	1
2	347	PS	Optanium	GOP-2PSP32-SC	46	0.88		0.14	60/16		
<b>F32T8/ES (28W)</b>											
1	347	PS	Optanium	GOP-2PSP32-SC	30	1.03	10	0.09	60/16	B	1
2	347	PS	Optanium	GOP-2PSP32-SC	50	0.88		0.15	60/16		
<b>F32T8/ES (30W)</b>											
1	347	PS	Optanium	GOP-2PSP32-SC	31	1.03	10	0.09	60/16	B	1
2	347	PS	Optanium	GOP-2PSP32-SC	52	0.88		0.15	60/16		

## Wiring Diagrams/Dimensions

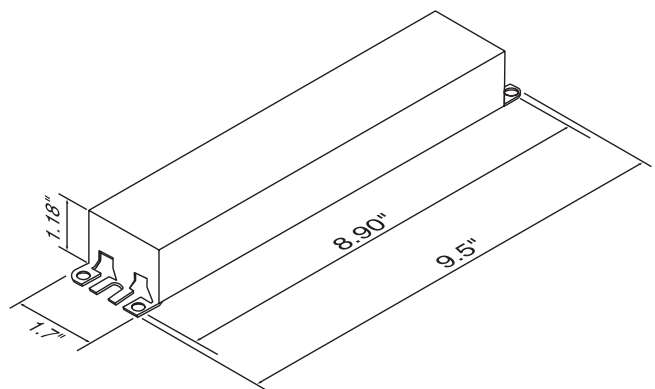
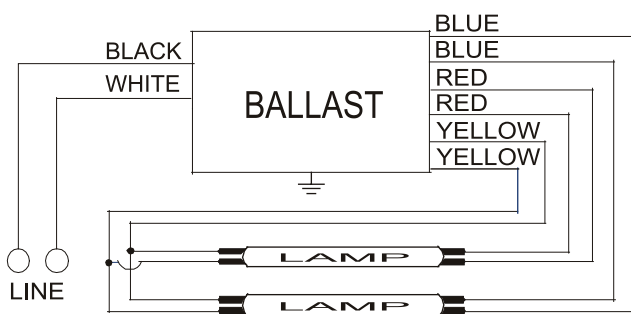

# Ballast Specifications

## Section I - Physical Characteristics

- 1.1 Ballast shall be physically interchangeable with standard electromagnetic or standard electronic ballasts, where applicable.
- 1.2 Ballast shall be provided with integral leads color-coded per ANSI C82.11.

## Section II - Performance Requirements

- 2.1 Ballast shall be Programmed Start.
- 2.2 Ballast shall provide Independent Lamp Operation (ILO) for Programmed Start ballasts allowing remaining lamp(s) to maintain full light output when one or more lamps fail.
- 2.3 Ballast shall contain auto restart circuitry in order to restart lamps without resetting power.
- 2.4 Ballast shall operate from 60 Hz input source of 120V through 277V or 347V as applicable with sustained variations of +/- 10% (voltage and frequency).
- 2.5 Ballast shall be high frequency electronic type and operate lamps at a frequency between 42kHz and 52kHz to avoid interference with infrared devices, eliminate visible flicker and avoid Article Surveillance System, such as anti-theft devices.
- 2.6 Ballast shall have a Power Factor greater than 0.98 for primary lamp.
- 2.7 Ballast shall have a minimum ballast factor for primary lamp application as follows: 0.75 for Low Watt, 0.85 for Normal Light Output, and 1.20 for High Light.
- 2.8 Ballast shall provide for a Lamp Current Crest Factor of 1.7 or less, generally recommended by lamp manufacturers.
- 2.9 Ballast input current shall have Total Harmonic Distortion (THD) of less than 10% when operated at nominal line voltage with primary lamp.
- 2.10 Ballast shall have a Class A sound rating for all 4-foot lamps and smaller.
- 2.11 Ballast shall have a minimum starting temperature of 0°F (-18°C) for standard lamps and 60°F (16°C) for energy-saving T8 lamps.
- 2.12 Ballast shall tolerate sustained open circuit and short circuit output conditions.
- 2.13 Ballast shall have lamp striation-reduction circuitry.

## Section III - Regulatory Requirements

- 3.1 Ballast shall not contain any Polychlorinated Biphenyl (PCB).
- 3.2 Ballast shall be Underwriters Laboratories (UL) listed, Class P and Type 1 Outdoor; and Canadian Standards Association (CSA) certified where applicable.
- 3.3 Ballast shall comply with ANSI C62.41 Category A for Transient protection.
- 3.4 Ballast shall comply with ANSI C82.11 where applicable.
- 3.5 Ballast shall comply with the requirements of the Federal Communications Commission (FCC) rules and regulations, Title 47 CFR part 18, Non-Consumer (Class A) for EMI/RFI (conducted and radiated).
- 3.6 Ballast shall meet NEMA/

## Section IV - Other

- 4.1 Ballast shall be manufactured in a factory certified to ISO 9002 Quality System Standards.
- 4.2 Ballast shall carry a \_\_\_ limited warranty from date of manufacture against defects in material or workmanship. This warranty is conditioned upon operation at a maximum case temperature of \_\_\_\_\_, among other items. (Go to our website for up-to-date warranty information, [www.philips.com/advancewarranty](http://www.philips.com/advancewarranty)).
- 4.3 Manufacturer shall have a twenty-year history of producing electronic ballasts for the North American market.
- 4.4 Ballast shall be Philips Advance part # \_\_\_\_\_ or approved equal.



©2011 Philips Lighting Electronics N.A.,  
A Division of Philips Electronics North America Corporation

All rights reserved.  
Printed in the USA

Form No. EL-2540-B

Philips Lighting Electronics N.A.  
10275 West Higgins Road  
Rosemont, IL 60018  
Tel: 800-322-2086 Fax: 888-423-1882  
Customer Support/Customer Care: 800-372-3331  
OEM Support: 866-915-5886  
[www.philips.com/advance](http://www.philips.com/advance)